

Name: _____

Date: _____

Electrical/Electronic Systems Work Example 1

WorkKey Level: 4

NATEF Automotive Task: VI.D.1

The specs for this alternator reads...puts out 90% of output. The alternator reads 112 amps and has a rated output of 135 amps.

- Is this within specs?
- What would the acceptable performance limit have to be in order for this to be an acceptable reading?
- What would the alternator have to produce to be within 90% of the rated output?

Electrical/Electronic Systems Work Example 2

WorkKey Level: 3

NATEF Automotive Tasks: VI.B.1

While testing a battery under no load, the battery has 12 1/4 volts. What is the approximate state of charge percentage according to the chart below?

Open circuit volts	Percentage of charge OR State of charge
11.7 volts or less	0%
12.0 volts	25%
12.2 volts	50%
12.4 volts	75%
12.6 volts or more	100%

Electrical/Electronic Systems Work Example 3

WorkKey Level: 4

NATEF Automotive Tasks: VI.B.2

During a battery capacity test, 50% of the cold cranking amperage should be pulled for 15 seconds.

On a battery with a rating of 700 cold cranking amps, how many amps should be drawn from the battery for the test?

Electrical/Electronic Systems Work Example 4

WorkKey Level: 3

NATEF Automotive Tasks: VI.A

Look at the voltmeter below. The spec sheet says that the voltage drop must be less than 0.3 volt. Which of the following readings is (are) acceptable?

400mv 300mv 200mv 100mv None are acceptable.

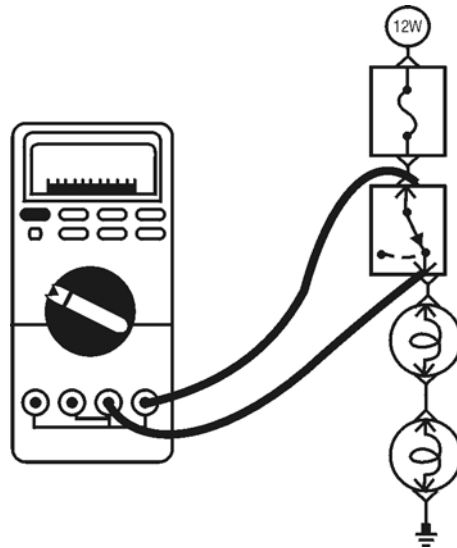

Electrical/Electronic Systems Work Example 5

WorkKey Level: 3

NATEF Automotive Tasks: VI.A

Which of the following readings is (are) acceptable if the spec sheet states that the voltage drop must be less than 0.5 volts?

0.500v 0.050v 0.005v 5.000mv none

Electrical/Electronic Systems Work Example 6

WorkKey Level: 4

NATEF Automotive Tasks: VI.A

You are checking voltage at a switch. There are 12.2 volts at Terminal A and 11.4 volts at Terminal B. What is the voltage drop?

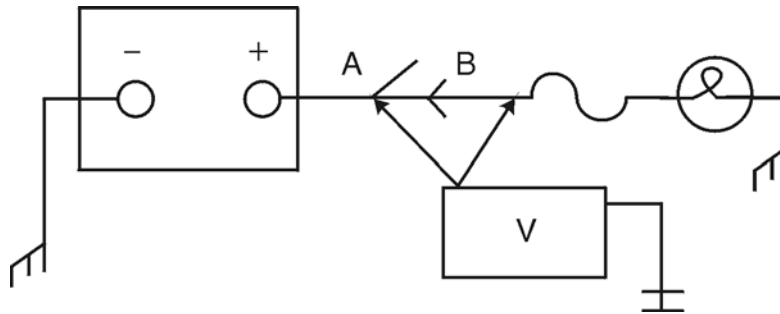

Electrical/Electronic Systems Work Example 7

WorkKey Level: 6

NATEF Automotive Tasks: VI.A.12, VI.A.14, VI.H.7

The customer wants to know if he can attach his power booster to his radio circuit. His power booster uses 200 watts; can he attach it to the radio circuit? Use Ohm's law to show him if he can or cannot do this.

Use the drawing and chart to show the customer where he can hook up his power booster. (The battery voltage is 12.6.)

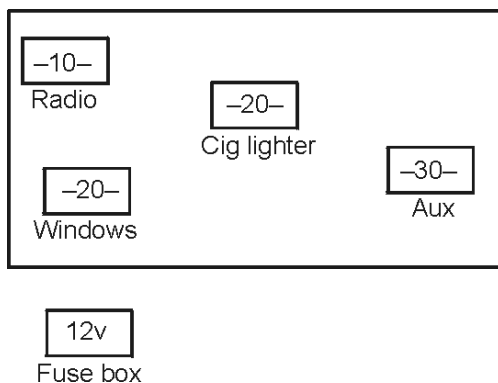

$$V = I \times R = \text{Ohm's law}$$

+	Component	Amp
Key On	Radio	6
Key On	Cig lighter	10
Key On	Windows	15
Always	Aux	Open

Electrical/Electronic Systems Work Example 8

WorkKey Level: 4

NATEF Automotive Tasks: VI.A.10, VI.A.12

What is the reading on the ohmmeter shown below? Where would the needle point if the switch was moved to x1000?

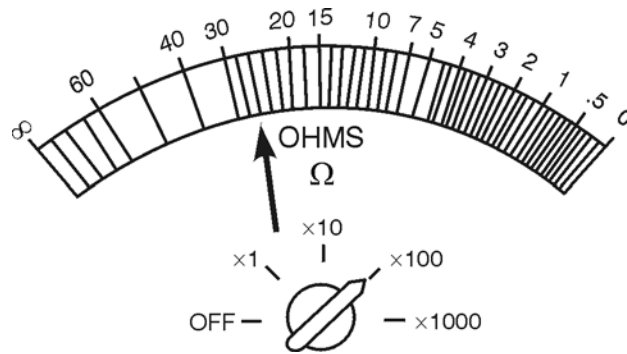

Electrical/Electronic Systems Work Example 9

WorkKey Level: 4

NATEF Automotive Tasks: VI.B.1

You must determine whether a battery should be replaced. You take a specific gravity reading of each cell. The readings are as follows:

Cell	Reading
1	1.145
2	1.182
3	1.131
4	1.131
5	1.158
6	1.173

Your service manual states that a battery must be replaced if there is a range of 0.050 (50 points) in the specific gravity readings of the cell.

- What is the lowest specific gravity reading of the cells?

- b. What is the highest specific gravity reading of the cells?
- c. What is the range of the specific gravity readings of the cells?
- d. Should you replace the battery?
- e. How can you explain the need for a new battery to a customer?

Electrical/Electronic Systems Work Example 10

WorkKey Level: 4

NATEF Automotive Tasks: VI.B.1

Open-circuit voltage test (sealed batteries)

Your service manual states that the battery must pass the *state-of-charge* or *open-circuit voltage test* before a *capacity test*, which provides a realistic determination for battery replacement. If the battery shows less than 12.2 volts, it should be recharged before the *capacity test*. If the state of charge is 75% or more, the battery is considered charged. Using a digital multimeter (DMM) set on DC volts, you perform an “Open-circuit voltage test” by checking the voltage across the positive and negative battery terminals. The results of this test can indicate a battery’s state of charge. You measure 11.8 volts at 80°F on the *open-circuit voltage test*.

Open-circuit voltage	State of charge at 80°F
12.6 or greater	100%
12.4 to 12.6 volts	70%–100%
12.2 to 12.4 volts	50%–75%
11.7 to 12.0 volts	0%–25%
11.7 or less	0%

- a. What voltage reading indicates a 100% charge?
- b. What does your reading indicate?
- c. What reading indicates a 75% charge?
- d. Should you recharge or replace the battery?
- e. How can you explain the need for a new battery to a customer?

Electrical/Electronic Systems Work Example 11

WorkKey Level: 5

NATEF Automotive Tasks:

When you apply your brake, all three brake lights are dim. The two brake lights each have a resistance of 2 ohms. The center brake light has a resistance of 4 ohms. Your meter reads 4 ohms at the base of the parallel circuit. Is the reading within the circuit's parameter?

Electrical/Electronic Systems Work Example 12

WorkKey Level: 5

NATEF Automotive Tasks:

On a parallel circuit, R_1 is 2 ohms and R_2 is 4 ohms. Find the total resistance and total current draw on a 12-V battery.

Electrical/Electronic Systems Work Example 13

WorkKey Level: 4

NATEF Automotive Tasks:

The lights are not working in a car and you are testing several electrical components.

When you test the wiring for your headlight the amp meter gives a reading of 2.5 amps.

The headlight has a resistance of 5 Ω .

Is there a problem in the wiring?

Electrical/Electronic Systems Work Example 14

WorkKey Level: 4

NATEF Automotive Tasks:

Ohm's law states that $E = I * R$ where E = voltage, I = amperage, and R = resistance. Find the resistance if the voltage is 12 and the amperage is 2.

Electrical/Electronic Systems Work Example 15

WorkKey Level: 4

NATEF Automotive Tasks:

The reading on the ohmmeter is 0.342 and the switch is on 2k ohms.

- a) What is the reading in ohms?
- b) What is the reading in milliohms?

Electrical/Electronic Systems Work Example 16

WorkKey Level: 3

NATEF Automotive Tasks:

In a series circuit the sum of the resistors equals the total resistance of the circuit.

In a circuit, resistor 1 = 3 ohms and resistor 2 = 8 ohms.

What is the total resistance of the series circuit?

Electrical/Electronic Systems Work Example 17

WorkKey Level: 5

NATEF Automotive Tasks:

You are helping a buddy install a light bar on his four-wheel-drive truck, which has a 12-volt battery. It uses four huge spotlights so he can 4 wheel at night. They are hooked up in parallel and use 1-ohm-resistance bulbs.

He is continually blowing 30-amp fuses!

Does he have a short or is the fuse too small? Oh yeah? Well—prove it!

Total
circuit
resistance

$$R_t = \frac{1}{\frac{1}{R_1} + \frac{1}{R_2} + \frac{1}{R_3} + \frac{1}{R_4}}$$

Your
circuit

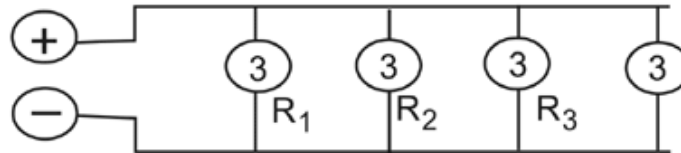

Ohm's law $E = I \times R$

1. Calculate total circuit resistance using the attached diagram. _____
2. Use Ohm's law to figure the current. _____
3. Determine the problem.

Electrical/Electronic Systems Work Example 18

WorkKey Level: 4

NATEF Automotive Tasks: VI.A.8

The voltage drop in an automotive starter relay switch is 0.4 volt. There are 12.7 volts at terminal "D." What is the voltage at terminal "E"?

Electrical/Electronic Systems Work Example 19

WorkKey Level: 6

NATEF Automotive Tasks:

A given V8 will have an ideal current draw of 200 amps. The specs allow for a tolerance of $\pm 10\%$. Starter circuit resistance is 0.03 and battery voltage is 12.6 V. Will the circuit fall within specifications?